

**COOK MEMORIAL PUBLIC LIBRARY DISTRICT  
413 N. MILWAUKEE AVENUE  
LIBERTYVILLE, ILLINOIS 60048**

July 19, 2022

Board Meeting  
6:30 p.m.

The regular meeting of the Board of Library Trustees of the Cook Memorial Public Library District scheduled for Tuesday, July 19, 2022 will be held in the Meeting Room at the Cook Park Library, 413 N Milwaukee Ave., Libertyville, Illinois.

1. Call to order.
2. Pledge of Allegiance.
3. Roll Call.
4. Public Comment.
5. Approval of the Minutes.
  - a. Minutes of the Regular Meeting of June 21, 2022.
6. Approval of Change Orders for Cook Park Window Replacement Project.
  - a. Contract 2, Change Order 1, Manusos General Contracting, in the amount of \$4,931.
  - b. Contract 3, Change Order 5, Prime Architectural Metal and Glass, in the amount of \$3,342.
7. Approval of the Bills.
8. Report of the Director.
  - a. Statistical Report.
  - b. Narrative Report.
  - c. Personnel Report.
  - d. Investment Report.
9. Report of the President.
10. Reports of Committees and Representatives.
  - a. Finance and Employee Practices.
  - b. Policy Review.
  - c. Building and Grounds
  - d. Development.
  - e. Technology.

- f. Resources, Services and Long Range Planning.
  - i. Strategic Plan Update.
  - g. Village of Libertyville Parking Commission Representative.
  - h. Friends' Representative.
  - i. RAILS Representative.
  - j. Historical Society Representative.
- 11. Other Business.
- 12. Communications.
- 13. Upcoming Meetings and Events.
  - a. Regular Board Meeting on Tuesday, August 16, 2022 at 6:30 p.m. at the Aspen Drive Library.
  - b. Finance Committee Meeting on Monday, August 22, 2022 at 6:30 p.m. at Location TBD.
- 14. Public Questions.
- 15. Adjournment.

Wendy Vieth, President  
Board of Library Trustees

July 14, 2022

*Any person needing an accommodation for a disability in order to attend a meeting at the Library should contact the Administration Office by phone at (847)362-2330, by email at ADA@cooklib.org or in writing, not less than five working days prior to the meeting.*



# Cook Memorial Public Library District

## LIBRARY BOARD MEETING AGENDA SUPPLEMENT

MEETING DATE: July 19, 2022

FROM: David Archer, Library Director

AGENDA ITEM: #6 - Approval of Change Order for Cook Park Window Replacement Project

---

The following change orders have been submitted by Featherstone and Product Architects for the Board's review and approval:

1. Contract 2, Change Order 1, Manusos General Contracting, in the amount of \$4,931  
Add one layer of drywall on top of the existing soffit\* in the south end of the fiction room's clerestory (high) windows. The initial design was measured and based off a portion of the section that has sufficient dimension to accommodate the depth of new window system. However, it was discovered that areas of the existing soffit are not a consistent depth, which means that without the additional layer of drywall, the windows would "hang-off" along the interior face.

\*Any finishing material, such as wood or fiber cement, that is installed to cover the underside of the roof overhang

2. Contract 3, Change Order 5, Prime Architectural Metal and Glass, in the amount of \$3,342  
Furnish and install counter flashing (waterproofing) at the sill (base) of windows. This pricing should have been included with a change order previously approved by the board.



# Featherstone, Inc.

PROJECT + CONSTRUCTION MANAGEMENT

4610 Roslyn Road, Downers Grove, Illinois 60515  
P 630.737.1990 www.featherstoneinc.com

## CHANGE ORDER

Project : Cook Memorial Library - Curtainwall  
& Aspen Entrance Improvements

Date : July 11, 2022

Contract : Carpentry, Drywall, Plaster,  
Acoustical Ceilings

C.O. # 001

To : Manusos General Contracting, Inc.

You are directed to make the following change to the Contract:

Add to the contract the following:

1	Change Event # 018 - laminating 5/8" existing soffit due to glazing thickness	4,931.00
---	---	----------

Consideration:

Contract Amount is Revised By: \$4,931.00

The contract time will not be changed by this Change Order by \_\_\_\_\_

Not valid until signed by the Owner and the Project Manager.

\_\_\_\_\_  
Cook Memorial Public Library

\_\_\_\_\_  
Architect

\_\_\_\_\_  
Project Manager

\_\_\_\_\_  
Contractor

CHANGE ORDER AMOUNT 4,931.00



91 Christopher Way  
Fox Lake, IL 60020  
Phone: (847) 973-0600  
Fax: (847) 973-0900

*Certified Women's Business Enterprise  
City of Chicago, CMS*

July 13, 2022

Featherstone, Inc.  
4610 Roslyn Road  
Downers Grove, Il 60515

Attention: Annica Mosow

Re: Cook Memorial  
Curtain wall/Storefront.

Dear Ms. Mosow:

Enclosed herein is the formalized quote as requested:

The cost to laminate a layer of 5/8 " drywall on top of the existing soffit would be \$4,931.00

(Material - \$635 Labor 32Hrs - \$4,296)

Respectfully submitted,

MANUSOS GENERAL CONTRACTING, INC.

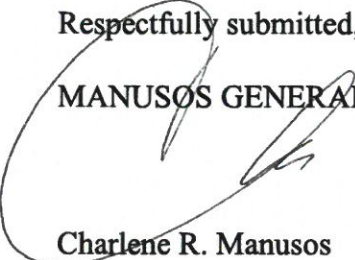

Charlene R. Manusos  
President



# Featherstone, Inc.

PROJECT + CONSTRUCTION MANAGEMENT

4610 Roslyn Road, Downers Grove, Illinois 60515  
P 630.737.1990 www.featherstoneinc.com

## CHANGE ORDER

Project : Cook Memorial Library - Curtainwall  
& Aspen Entrance Improvements

Date : July 11, 2022

Contract : Storefronts, Glass, & Glazing  
To : Prime Architectural Metal and  
Glass

C.O. # 005

You are directed to make the following change to the Contract:

Add to the contract the following:

1 Change Event # 016 - Additional Break Metal at Sill of Storefronts 3,342.00

Consideration:

Contract Amount is Revised By: \$3,342.00

The contract time will not be changed by this Change Order by

Not valid until signed by the Owner and the Project Manager.

Cook Memorial Public Library

Architect

Project Manager

Contractor

CHANGE ORDER AMOUNT 3,342.00



Ph.(847)891-3725 Fax (847)891-6063

## Change Order Request #5

June 14, 2022  
 Featherstone, Inc.  
 4610 Roslyn Road  
 Downers Grove, IL 60515  
 Attn: Annica Mosow

Project: Cook Park Library Project  
 Re: Additional break metal

Annica:

Based on the return submittals shop drawings of storefront and curtainwall dated 06/06/2022, please see the cost implications to furnish and install counterflashing and adding an upturn leg at the sill of storefront elevations to Cook Park Library project and advise if this change is acceptable. See below the updated detail. This is incorporated in the revised shop drawings.

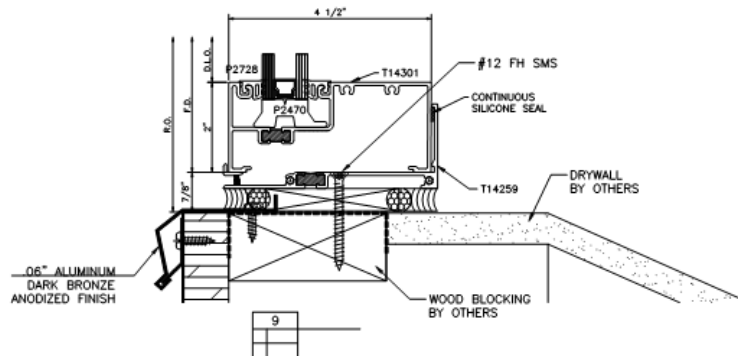

Added Break metal material cost	\$1,640.00
4 hours of Shop labor @ \$50 per hour	\$ 200.00
Overhead & Profit (15%)	\$ 276.00
4 hours General Foreman Ironworker @ \$149.61 per hour	\$ 598.44
4 hours Journeyman Ironworker @ \$144.51 per hour	\$ 578.04
Bond Cost (1.5%)	\$ 49.39
Total change order request:	\$3,342.00

Let me know if you have any questions/comments.

Thank you,  
 Khaja Ali  
 Project Manager

**926 Lunt Ave. Schaumburg, IL. 60193**

**COOK MEMORIAL PUBLIC LIBRARY DISTRICT**  
**Balance Sheet by Fund**  
As of June 30, 2022 - Preliminary

	<u>10-General</u>	<u>20-IMRF</u>	<u>30-Working Cash</u>	<u>40-Early Property Tax</u>	<u>50-Trust</u>	<u>60-Special Reserve</u>	<u>TOTAL</u>
<b>ASSETS</b>							
<b>Current Assets</b>							
<b>Checking/Savings</b>							
<b>1000 - Cash</b>							
10-1040 - Petty Cash	625						625
10-1045 - Cash on Hand - Aspen	60						60
10-1150 - Chase Operating A/C	134,886	152,599	555,776	2,867,913	24,073	202,540	3,937,787
10-1504 - Illinois Funds - General, IMRF	298,690	37,443				323,236	659,369
10-1509 - Wintrust MaxSafe Acct - General	2,493,429			1,500,000			3,993,429
60-1509 - Wintrust MaxSafe Acct - S/R						1,234,636	1,234,636
10-1550 - Chase Savings Account							
10-1551 - Chase Savings - GF	56,479						56,479
60-1551 - Chase Savings - SRF						201,068	201,068
<b>Total 10-1550 - Chase Savings Account</b>	<u>56,479</u>					<u>201,068</u>	<u>257,547</u>
<b>Total 1000 - Cash</b>	<u>2,984,169</u>	<u>190,042</u>	<u>555,776</u>	<u>4,367,913</u>	<u>24,073</u>	<u>1,961,480</u>	<u>10,083,453</u>
<b>2000 - Investments</b>							
<b>10-1502 - Investments - General Fund</b>							
10-1651 - Investments - Chase (GF)	860,000						860,000
<b>Total 10-1502 - Investments - General Fund</b>	<u>860,000</u>						<u>860,000</u>
<b>60-1501 - Investments - Special Reserve</b>							
60-1651 - Investments - Chase (SRF)						1,595,000	1,595,000
<b>Total 60-1501 - Investments - Special Reserve</b>						<u>1,595,000</u>	<u>1,595,000</u>
<b>Total 2000 - Investments</b>	<u>860,000</u>					<u>1,595,000</u>	<u>2,455,000</u>
<b>Total Checking/Savings</b>	<u>3,844,169</u>	<u>190,042</u>	<u>555,776</u>	<u>4,367,913</u>	<u>24,073</u>	<u>3,556,480</u>	<u>12,538,453</u>
<b>Other Current Assets</b>							
10-1990 - Friends of the Library 2	18,301						18,301
<b>Total Other Current Assets</b>	<u>18,301</u>						<u>18,301</u>
<b>Total Current Assets</b>	<u>3,862,470</u>	<u>190,042</u>	<u>555,776</u>	<u>4,367,913</u>	<u>24,073</u>	<u>3,556,480</u>	<u>12,556,754</u>
<b>TOTAL ASSETS</b>	<u><b>3,862,470</b></u>	<u><b>190,042</b></u>	<u><b>555,776</b></u>	<u><b>4,367,913</b></u>	<u><b>24,073</b></u>	<u><b>3,556,480</b></u>	<u><b>12,556,754</b></u>
<b>LIABILITIES &amp; EQUITY</b>							
<b>Liabilities</b>							
<b>Current Liabilities</b>							
<b>Accounts Payable</b>							
20000 - Accounts Payable	0						0
<b>Total Accounts Payable</b>	<u>0</u>						<u>0</u>
<b>Credit Cards</b>							
10-2050 - Chase One Card	8,739						8,739
<b>Total Credit Cards</b>	<u>8,739</u>						<u>8,739</u>
<b>Other Current Liabilities</b>							
00-2100 - Payroll W/H & Payable							
10-2850 - Aflac Payable	93						93



**COOK MEMORIAL PUBLIC LIBRARY DISTRICT**  
**Balance Sheet by Fund**  
As of June 30, 2022 - Preliminary

	<u>10-General</u>	<u>20-IMRF</u>	<u>30-Working Cash</u>	<u>40-Early Property Tax</u>	<u>50-Trust</u>	<u>60-Special Reserve</u>	<u>TOTAL</u>
10-2300 · IMRF Payable-Employee Medicare	(11)						(11)
10-2600 · IMRF Voluntary Life Insurance	208						208
10-2700 · Dental and Vision	1,140						1,140
10-2800 · CO-OP 90's Medical Plan	4,495						4,495
10-2900 · Other Health Care-FSA	6,167						6,167
<b>Total 00-2100 · Payroll W/H &amp; Payable</b>	<b>12,092</b>						<b>12,092</b>
20-2300 · IMRF Payable-Employer Medicare		0					0
40-2011 · Due To/From Gen Fund-Prop Tax				3,990,188			3,990,188
40-2014 · Due To/From IMRF Fund-Prop Tax				377,725			377,725
<b>Total Other Current Liabilities</b>	<b>12,092</b>	<b>0</b>		<b>4,367,913</b>			<b>4,380,005</b>
<b>Total Current Liabilities</b>	<b>20,831</b>	<b>0</b>		<b>4,367,913</b>			<b>4,388,744</b>
<b>Total Liabilities</b>	<b>20,831</b>	<b>0</b>		<b>4,367,913</b>			<b>4,388,744</b>
<b>Equity</b>							
<b>00-3000 · Beginning Fund Balances</b>							
10-3000 · Fund Balance-General Fund	3,624,644						3,624,644
10-3010 · Assigned FB - Computer/Tech Res	365,000						365,000
10-3011 · Assigned FB - Bookmobile Res.	100,000						100,000
20-3000 · Fund Balance - IMRF Fund		148,591					148,591
30-3000 · Fund Balance-Working Cash Fund			555,776				555,776
50-3000 · Fund Balance-Trust Fund					23,873		23,873
60-3000 · Fund Balance-Spec Reserve Fund						2,961,246	2,961,246
<b>Total 00-3000 · Beginning Fund Balances</b>	<b>4,089,644</b>	<b>148,591</b>	<b>555,776</b>		<b>23,873</b>	<b>2,961,246</b>	<b>7,779,130</b>
<b>Net Income</b>	<b>(248,004)</b>	<b>41,451</b>			<b>200</b>	<b>595,235</b>	<b>388,882</b>
<b>Total Equity</b>	<b>3,841,640</b>	<b>190,042</b>	<b>555,776</b>		<b>24,073</b>	<b>3,556,481</b>	<b>8,168,012</b>
<b>TOTAL LIABILITIES &amp; EQUITY</b>	<b>3,862,471</b>	<b>190,042</b>	<b>555,776</b>	<b>4,367,913</b>	<b>24,073</b>	<b>3,556,481</b>	<b>12,556,756</b>
<b>UNBALANCED CLASSES</b>	<b>0</b>						<b>0</b>

COOK MEMORIAL PUBLIC LIBRARY DISTRICT

Profit & Loss by Fund

July 2021 through June 2022 - Preliminary

	<u>10-General</u>	<u>20-IMRF</u>	<u>50-Trust</u>	<u>60-Special Reserve</u>	<u>TOTAL</u>
<b>Ordinary Income/Expense</b>					
<b>Income</b>					
00-4000 · Property Tax	8,703,543	834,008	0	0	9,537,551
00-4050 · Replacement Tax	252,621	0	0	0	252,621
00-4100 · Interest Earned	14,785	0	0	6,488	21,273
00-4200 · Other	19,494	0	200	0	19,694
10-4300 · Grants & Other Donations	92,240	0	0	0	92,240
10-4350 · Fines	16,464	0	0	0	16,464
<b>Total Income</b>	<u>9,099,147</u>	<u>834,008</u>	<u>200</u>	<u>6,488</u>	<u>9,939,843</u>
<b>Gross Profit</b>	9,099,147	834,008	200	6,488	9,939,843
<b>Expense</b>					
10-5100 · Salaries	4,629,661	0	0	0	4,629,661
10-5200 · Benefits	452,038	0	0	0	452,038
10-5300 · Training	22,111	0	0	0	22,111
10-5400 · Materials	1,120,312	0	0	0	1,120,312
10-5500 · Processing	41,197	0	0	0	41,197
10-5600 · Supplies	108,660	0	0	0	108,660
10-5700 · Vehicles	10,942	0	0	0	10,942
10-5800 · Computer Operations	438,494	0	0	0	438,494
10-5900 · Utilities	168,754	0	0	0	168,754
10-6000 · Telephone	27,089	0	0	0	27,089
10-6100 · Postage	9,373	0	0	0	9,373
10-6200 · Maintenance	117,382	0	0	0	117,382
10-6300 · Repair	56,261	0	0	0	56,261
10-6400 · Insurance	55,079	0	0	0	55,079
10-6500 · Professional Services	70,744	0	0	0	70,744
10-6600 · Improvements	28,717	0	0	0	28,717
10-6700 · Community Relations	166,206	0	0	0	166,206
10-7000 · Debt Service	981,132	0	0	0	981,132
20-8210 · Employer IMRF Disbursements	0	447,612	0	0	447,612
20-8250 · Employer Soc Security Tax Disb	0	344,946	0	0	344,946
<b>Total Expense</b>	<u>8,504,152</u>	<u>792,558</u>	<u>0</u>	<u>0</u>	<u>9,296,710</u>
<b>Net Ordinary Income</b>	594,995	41,450	200	6,488	643,133

**COOK MEMORIAL PUBLIC LIBRARY DISTRICT**  
**Profit & Loss by Fund**

July 2021 through June 2022 - Preliminary

	<u>10-General</u>	<u>20-IMRF</u>	<u>50-Trust</u>	<u>60-Special Reserve</u>	<u>TOTAL</u>
<b>Other Income/Expense</b>					
<b>Other Income</b>					
10-9910 · Interfund Transfers - General	-843,000	0	0	0	-843,000
60-9960 · Interfund Transfers-Spec Reserv	0	0	0	843,000	843,000
<b>Total Other Income</b>	<u>-843,000</u>	<u>0</u>	<u>0</u>	<u>843,000</u>	<u>0</u>
<b>Other Expense</b>					
60-9800 · Special Reserve Disbursements	0	0	0	254,253	254,253
<b>Total Other Expense</b>	<u>0</u>	<u>0</u>	<u>0</u>	<u>254,253</u>	<u>254,253</u>
<b>Net Other Income</b>	<u>-843,000</u>	<u>0</u>	<u>0</u>	<u>588,747</u>	<u>-254,253</u>
<b>Net Income</b>	<u><u>-248,005</u></u>	<u><u>41,450</u></u>	<u><u>200</u></u>	<u><u>595,235</u></u>	<u><u>388,880</u></u>

### COOK MEMORIAL PUBLIC LIBRARY DISTRICT Monthly Budget Report June 2022 - Preliminary

	June 2022				Year To Date June 2022				Annual Budget		Annual Appropriation	
	Actual	Budget	Var \$	Var %	Actual	Budget	Var \$	Var %	% of Budget	\$	% of Approp	\$
<b>Ordinary Income/Expense</b>												
<b>Income</b>												
00-4000 · Property Tax	0	0	0	0.00%	9,537,551	9,541,000	(3,449)	-0.04%	99.96%	9,541,000		
00-4050 · Replacement Tax	0	0	0	0.00%	252,621	112,000	140,621	125.55%	225.55%	112,000		
00-4100 · Interest Earned	5,184	1,750	3,434	196.23%	21,272	21,000	272	1.30%	101.30%	21,000		
00-4200 · Other	1,326	1,000	326	32.57%	19,694	12,000	7,694	64.11%	164.11%	12,000		
10-4300 · Grants & Other Donations	152	7,300	(7,148)	-97.92%	92,240	88,000	4,240	4.82%	0.00%	88,000		
10-4330 · Friends of The Library	0	0	0	0.00%	0	0	0	0.00%	0.00%	0		
10-4350 · Fines	1,387	250	1,137	454.96%	16,464	3,000	13,464	448.80%	548.80%	3,000		
<b>Total Income</b>	<b>8,049</b>	<b>10,300</b>	<b>(2,251)</b>	<b>-21.85%</b>	<b>9,939,842</b>	<b>9,777,000</b>	<b>162,842</b>	<b>1.67%</b>	<b>101.67%</b>	<b>9,777,000</b>	<b>0.00%</b>	<b>0</b>
<b>Expense</b>												
10-5100 · Salaries	361,414	370,544	9,130	2.46%	4,629,661	4,742,000	112,339	2.37%	#DIV/0!	4,742,000	0.00%	4,979,000
10-5200 · Benefits	31,762	43,467	11,705	26.93%	452,038	522,000	69,962	13.40%	86.60%	522,000	0.00%	548,000
10-5300 · Training	787	2,979	2,192	73.57%	22,111	40,000	17,889	44.72%	55.28%	40,000	0.00%	45,000
10-5400 · Materials	140,874	98,056	(42,818)	-43.67%	1,120,312	1,235,000	114,688	9.29%	90.71%	1,235,000	0.00%	1,250,000
10-5500 · Processing	5,461	3,169	(2,292)	-72.34%	41,197	39,000	(2,197)	-5.63%	105.63%	39,000	0.00%	42,000
10-5600 · Supplies	23,392	10,155	(13,237)	-130.35%	108,660	130,000	21,340	16.42%	83.58%	130,000	0.00%	148,000
10-5700 · Vehicles	1,075	2,489	1,414	56.83%	10,942	30,000	19,058	63.53%	36.47%	30,000	0.00%	35,000
10-5800 · Computer Operations	62,270	54,380	(7,890)	-14.51%	438,494	535,000	96,506	18.04%	81.96%	535,000	0.00%	580,000
10-5900 · Utilities	13,117	14,799	1,682	11.37%	168,754	185,000	16,246	8.78%	91.22%	185,000	0.00%	205,000
10-6000 · Telephone	3,114	2,013	(1,101)	-54.68%	27,089	33,000	5,911	17.91%	82.09%	33,000	0.00%	40,000
10-6100 · Postage	1,000	978	(22)	-2.25%	9,373	12,000	2,627	21.90%	78.11%	12,000	0.00%	15,000
10-6200 · Maintenance	9,741	12,330	2,589	21.00%	117,382	180,000	62,618	34.79%	65.21%	180,000	0.00%	199,000
10-6300 · Repair	4,528	9,319	4,791	51.41%	56,261	136,000	79,739	58.63%	41.37%	136,000	0.00%	153,000
10-6400 · Insurance	0	0	0	0.00%	55,079	70,000	14,921	21.32%	#DIV/0!	70,000	0.00%	80,000
10-6500 · Professional Services	9,728	5,604	(4,124)	-73.59%	70,744	98,000	27,256	27.81%	72.19%	98,000	0.00%	108,000
10-6600 · Improvements	2,107	3,824	1,717	44.89%	28,717	67,000	38,283	57.14%	42.86%	67,000	0.00%	80,000
10-6700 · Community Relations	55,505	39,328	(16,177)	-41.13%	166,206	186,000	19,794	10.64%	89.36%	186,000	0.00%	195,000
10-6800 · Rent	0	0	0	0.00%	0	0	0	0.00%	0.00%	0	0.00%	5,000
10-6900 · Contingency	0	4,166	4,166	100.00%	0	50,000	50,000	100.00%	0.00%	50,000	0.00%	50,000
10-7000 · Debt Service	0	0	0	0.00%	981,132	983,000	1,868	0.19%	99.81%	983,000	0.00%	985,000
10-8010 · Capital Improvement Projects	0	9,168	9,168	100.00%	0	110,000	110,000	100.00%	0.00%	110,000	0.00%	110,000
20-8210 · Employer IMRF Disbursements	31,531	41,167	9,636	23.41%	447,612	534,000	86,388	16.18%	83.82%	534,000	0.00%	561,000
20-8250 · Employer Soc Security Tax Disb	26,914	28,125	1,211	4.31%	344,946	360,000	15,054	4.18%	95.82%	360,000	0.00%	378,000
<b>Total Expense</b>	<b>784,321</b>	<b>756,060</b>	<b>(28,261)</b>	<b>-3.74%</b>	<b>9,296,707</b>	<b>10,277,000</b>	<b>980,293</b>	<b>9.54%</b>	<b>90.46%</b>	<b>10,277,000</b>	<b>0.00%</b>	<b>10,791,000</b>

**COOK MEMORIAL PUBLIC LIBRARY DISTRICT  
Monthly Budget Report  
June 2022 - Preliminary**

	June 2022				Year To Date June 2022				Annual Budget		Annual Appropriation	
	Actual	Budget	Var \$	Var %	Actual	Budget	Var \$	Var %	% of Budget	\$	% of Approp	\$
<b>Net Ordinary Income (Expense)</b>	(776,272)	(745,760)	(30,512)		643,135	(500,000)	1,143,135			(500,000)		
<b>Other Income/Expense:</b>												
<b>Other Income</b>												
10-9100 · Other Income	0				0		0					
10-9910 · Interfund Transfers - General	0		0		(843,000)		0					
60-9960 · Interfund Transfers - Special Reserve	0		0		843,000		0					
<b>Total Other Income</b>	0		0		0		0					
<b>Other Expense</b>												
10-9500 · Other Expense	0		0		0		0					
50-8500 · Trust Disbursements	0	0	0		0	0	0					
60-9800 · Special Reserve Disbursements	18,807	0	(18,807)		254,253	0	(254,253)					
<b>Total Other Expense</b>	18,807	0	(18,807)		254,253	0	(254,253)					
<b>Net Other Income/(Expense)</b>	(18,807)	0	(18,807)		(254,253)	0	(254,253)					
<b>Net Income</b>	(795,078)	(745,760)	(49,318)		388,882	(500,000)	888,882			(500,000)		

**COOK MEMORIAL PUBLIC LIBRARY DISTRICT**  
**Bills Paid Summary**

June 18 through July 15, 2022

	<u>10-General</u>	<u>20-IMRF</u>	<u>60-Special Reserve</u>	<u>TOTAL</u>
<b>Ordinary Income/Expense</b>				
<b>Income</b>				
00-4050 · Replacement Tax	44,857.30	0.00	0.00	44,857.30
00-4100 · Interest Earned	3,857.72	0.00	1,326.33	5,184.05
00-4200 · Other	1,339.99	0.00	0.00	1,339.99
10-4300 · Grants & Other Donations	152.01	0.00	0.00	152.01
10-4350 · Fines	1,373.43	0.00	0.00	1,373.43
<b>Total Income</b>	<u>51,580.45</u>	<u>0.00</u>	<u>1,326.33</u>	<u>52,906.78</u>
<b>Gross Profit</b>	51,580.45	0.00	1,326.33	52,906.78
<b>Expense</b>				
10-5100 · Salaries	365,348.85	0.00	0.00	365,348.85
10-5200 · Benefits	48,811.13	0.00	0.00	48,811.13
10-5300 · Training	574.63	0.00	0.00	574.63
10-5400 · Materials	123,448.30	0.00	0.00	123,448.30
10-5500 · Processing	120.00	0.00	0.00	120.00
10-5600 · Supplies	13,831.51	0.00	0.00	13,831.51
10-5700 · Vehicles	1,231.97	0.00	0.00	1,231.97
10-5800 · Computer Operations	71,538.39	0.00	0.00	71,538.39
10-5900 · Utilities	8,897.38	0.00	0.00	8,897.38
10-6000 · Telephone	3,129.95	0.00	0.00	3,129.95
10-6100 · Postage	1,000.00	0.00	0.00	1,000.00
10-6200 · Maintenance	9,071.80	0.00	0.00	9,071.80
10-6300 · Repair	10,778.00	0.00	0.00	10,778.00
10-6500 · Professional Services	1,446.97	0.00	0.00	1,446.97
10-6600 · Improvements	2,100.76	0.00	0.00	2,100.76
10-6700 · Community Relations	17,853.76	0.00	0.00	17,853.76
10-7000 · Debt Service	126,593.86	0.00	0.00	126,593.86
20-8210 · Employer IMRF Disbursements	0.00	31,947.73	0.00	31,947.73
20-8250 · Employer Soc Security Tax Disb	0.00	27,218.82	0.00	27,218.82
<b>Total Expense</b>	<u>805,777.26</u>	<u>59,166.55</u>	<u>0.00</u>	<u>864,943.81</u>
<b>Net Ordinary Income</b>	-754,196.81	-59,166.55	1,326.33	-812,037.03
<b>Other Income/Expense</b>				
<b>Other Expense</b>				

COOK MEMORIAL PUBLIC LIBRARY DISTRICT  
**Bills Paid Summary**

June 18 through July 15, 2022

	<u>10-General</u>	<u>20-IMRF</u>	<u>60-Special Reserve</u>	<u>TOTAL</u>
60-9800 - Special Reserve Disbursements	0.00	0.00	2,504.46	2,504.46
Total Other Expense	0.00	0.00	2,504.46	2,504.46
Net Other Income	0.00	0.00	-2,504.46	-2,504.46
Net Income	<u><u>-754,196.81</u></u>	<u><u>-59,166.55</u></u>	<u><u>-1,178.13</u></u>	<u><u>-814,541.49</u></u>

COOK MEMORIAL PUBLIC LIBRARY DISTRICT  
Bills Paid Report By Class

June 18 through July 15, 2022

	Date	Name	Paid Amount
<b>Ordinary Income/Expense</b>			
<b>Income</b>			
<b>00-4050 - Replacement Tax</b>			
<b>10-4050 - Replacement Tax General</b>			
	07/07/2022		44,857.30
Total 10-4050 - Replacement Tax General			44,857.30
Total 00-4050 - Replacement Tax			44,857.30
<b>00-4100 - Interest Earned</b>			
<b>60-3109 - Interest-Wintrust MaxSafe - S/R</b>			
	06/30/2022		1,134.88
Total 60-3109 - Interest-Wintrust MaxSafe - S/R			1,134.88
<b>10-3109 - Interest-Wintrust MaxSafe - Gen</b>			
	06/30/2022		3,834.61
Total 10-3109 - Interest-Wintrust MaxSafe - Gen			3,834.61
<b>10-3180 - Interest - Money Market Fund</b>			
	06/30/2022		0.00
Total 10-3180 - Interest - Money Market Fund			0.00
<b>10-4100 - Interest Earned-General Fund</b>			
<b>10-4101 - Interest Income - Chase Savings</b>			
	06/30/2022		2.30
Total 10-4101 - Interest Income - Chase Savings			2.30
<b>10-4102 - Interest Income - Chase CD's</b>			
	06/30/2022		20.81
Total 10-4102 - Interest Income - Chase CD's			20.81
Total 10-4100 - Interest Earned-General Fund			23.11
<b>60-4100 - Interest Earned Special Reserve</b>			
<b>60-4101 - Interest Income - Chase Savings</b>			
	06/30/2022		8.20
Total 60-4101 - Interest Income - Chase Savings			8.20
<b>60-4102 - Interest Income - Chase CD's</b>			
	06/30/2022		183.25
Total 60-4102 - Interest Income - Chase CD's			183.25



COOK MEMORIAL PUBLIC LIBRARY DISTRICT  
Bills Paid Report By Class

June 18 through July 15, 2022

	Date	Name	Paid Amount
Total 60-4100 · Interest Earned Special Reserve			191.45
Total 00-4100 · Interest Earned			5,184.05
<b>00-4200 · Other</b>			
<b>10-4400 · Lost Materials</b>			
	06/20/2022		27.40
	07/01/2022		40.07
	06/20/2022		39.56
	07/01/2022		59.97
	06/27/2022	PANOV, KATHY	27.00
	06/30/2022	SONG, CARREEN	-4.95
	06/30/2022	BROGAN, JAMIE	-9.99
	06/30/2022	GAS, NICOLE	-18.99
	06/30/2022	ROSKO, DAVE	-13.63
	06/30/2022	RUKSTALES, DEBRA	-17.99
	06/30/2022	STANIS, KORTNEY	-17.99
	07/15/2022	BROWN, KENRIC	-19.99
	07/15/2022	SOLING, ELIZABETH	-16.99
	06/30/2022	HAYEN, ROBIN	-5.99
	06/30/2022	PANOV, KATHY	-27.00
Total 10-4400 · Lost Materials			40.49
<b>10-4450 · Copy Machine Income</b>			
<b>10-4451 · Aspen - Print/Copy Station</b>			
	07/06/2022		828.45
Total 10-4451 · Aspen - Print/Copy Station			828.45
<b>10-4452 · Cook Park - Print/Copy Station</b>			
	07/06/2022		205.05
Total 10-4452 · Cook Park - Print/Copy Station			205.05
Total 10-4450 · Copy Machine Income			1,033.50
<b>10-4500 · Misc - General Account</b>			
	07/01/2022		76.00
	06/20/2022		24.00
	07/01/2022		166.00
Total 10-4500 · Misc - General Account			266.00

COOK MEMORIAL PUBLIC LIBRARY DISTRICT  
**Bills Paid Report By Class**

June 18 through July 15, 2022

	<u>Date</u>	<u>Name</u>	<u>Paid Amount</u>
Total 00-4200 · Other			1,339.99
<b>10-4300 · Grants &amp; Other Donations</b>			
<b>10-4365 · Donations - Other</b>			
	06/20/2022		100.00
	06/20/2022		324.00
	06/30/2022	Awards & Engraving - CMPL Credit Card	-271.99
			<u>152.01</u>
Total 10-4365 · Donations - Other			152.01
Total 10-4300 · Grants & Other Donations			152.01
<b>10-4350 · Fines</b>			
	06/20/2022		20.50
	07/01/2022		17.50
	06/20/2022		21.00
	07/01/2022		11.70
	06/30/2022		1,457.29
	06/30/2022		-154.56
			<u>1,373.43</u>
Total 10-4350 · Fines			1,373.43
Total Income			<u>52,906.78</u>
Gross Profit			52,906.78
<b>Expense</b>			
<b>10-5100 · Salaries</b>			
<b>10-5110 · Administration Salaries</b>			
	07/01/2022		34,773.13
	07/15/2022		34,859.29
			<u>69,632.42</u>
Total 10-5110 · Administration Salaries			69,632.42
<b>10-5120 · Adult Salaries</b>			
	07/01/2022		44,289.60
	07/15/2022		43,841.82
			<u>88,131.42</u>
Total 10-5120 · Adult Salaries			88,131.42
<b>10-5130 · Children's Salaries</b>			
	07/01/2022		30,589.94
	07/15/2022		30,421.89
			<u>61,011.83</u>
Total 10-5130 · Children's Salaries			61,011.83
<b>10-5140 · Circulation Salaries</b>			

COOK MEMORIAL PUBLIC LIBRARY DISTRICT  
Bills Paid Report By Class

June 18 through July 15, 2022

	<u>Date</u>	<u>Name</u>	<u>Paid Amount</u>
	07/01/2022		27,011.73
	07/15/2022		26,991.10
Total 10-5140 · Circulation Salaries			54,002.83
<b>10-5145 · Maintenance Salaries</b>			
	07/01/2022		8,098.26
	07/15/2022		7,306.15
Total 10-5145 · Maintenance Salaries			15,404.41
<b>10-5150 · ILL Salaries</b>			
	07/01/2022		3,802.25
	07/15/2022		3,845.02
Total 10-5150 · ILL Salaries			7,647.27
<b>10-5155 · Outreach Salaries</b>			
	07/01/2022		8,983.57
	07/15/2022		8,505.13
Total 10-5155 · Outreach Salaries			17,488.70
<b>10-5160 · Tech Services Salaries</b>			
	07/01/2022		20,345.56
	07/15/2022		20,419.66
Total 10-5160 · Tech Services Salaries			40,765.22
<b>10-5165 · Shelters Salaries</b>			
	07/01/2022		5,790.66
	07/15/2022		5,474.09
Total 10-5165 · Shelters Salaries			11,264.75
Total 10-5100 · Salaries			365,348.85
<b>10-5200 · Benefits</b>			
<b>10-5210 · Health Insurance</b>			
	07/01/2022	BLUE CROSS BLUE SHIELD OF ILLINOIS	4,254.17
	06/30/2022	NCPERS GROUP LIFE INS	224.00
	07/01/2022	BLUE CROSS BLUE SHIELD OF ILLINOIS	1,236.32
	07/15/2022	COOPERATIVE 90'S MEDICAL	30,490.50
	06/30/2022	AFLAC	92.52
	07/15/2022	COOPERATIVE 90'S MEDICAL	5,463.50
	06/30/2022		635.84

COOK MEMORIAL PUBLIC LIBRARY DISTRICT  
Bills Paid Report By Class

June 18 through July 15, 2022

	<u>Date</u>	<u>Name</u>	<u>Paid Amount</u>
	06/30/2022		317.46
	06/30/2022		494.93
	06/30/2022		100.00
Total 10-5210 · Health Insurance			<u>43,309.24</u>
<b>10-5220 · Dental/Vision Insurance</b>			
	06/20/2022		-45.00
	06/30/2022		-45.00
	06/20/2022		-49.19
	06/30/2022		-574.39
	06/30/2022	DELTA DENTAL OF ILLINOIS - VISION	93.55
	06/30/2022	DELTA DENTAL OF ILLINOIS - VISION	249.85
	07/15/2022	COOPERATIVE 90'S DENTAL	1,184.50
	07/15/2022	COOPERATIVE 90'S DENTAL	<u>3,090.50</u>
Total 10-5220 · Dental/Vision Insurance			3,904.82
<b>10-5230 · Unemployment Compensation</b>			
	07/15/2022	LIMRiCC UNEMPLOYMENT COMPENSATION GR	<u>949.29</u>
Total 10-5230 · Unemployment Compensation			949.29
<b>10-5240 · Life Insurance</b>			
	07/01/2022	MADISON NATIONAL LIFE INS CO., INC.	<u>265.54</u>
Total 10-5240 · Life Insurance			265.54
<b>10-5270 · LTD Insurance</b>			
	07/01/2022	MADISON NATIONAL LIFE INS CO., INC.	<u>382.24</u>
Total 10-5270 · LTD Insurance			<u>382.24</u>
Total 10-5200 · Benefits			48,811.13
<b>10-5300 · Training</b>			
<b>10-5310 · Workshops</b>			
<b>10-5315 · Workshops - Maintenance</b>			
	06/30/2022	HR Resource - CMPL Credit Card	<u>250.00</u>
Total 10-5315 · Workshops - Maintenance			<u>250.00</u>
Total 10-5310 · Workshops			250.00
<b>10-5320 · Travel</b>			
<b>10-5328 · Travel - Tech Services</b>			
	06/30/2022	KLINE, SANDY	3.63

COOK MEMORIAL PUBLIC LIBRARY DISTRICT

Bills Paid Report By Class

June 18 through July 15, 2022

	<u>Date</u>	<u>Name</u>	<u>Paid Amount</u>
Total 10-5328 · Travel - Tech Services			3.63
Total 10-5320 · Travel			3.63
<b>10-5330 · Memberships</b>			
<b>10-5332 · Memberships - Adults</b>			
	06/30/2022	American Library Assoc - CMPL Credit Card	212.00
Total 10-5332 · Memberships - Adults			212.00
Total 10-5330 · Memberships			212.00
<b>10-5360 · Personnel Tools</b>			
	06/28/2022	LAKE COUNTY CLERK	-10.00
	06/30/2022	National Notary Assoc. - CMPL Credit Card	119.00
Total 10-5360 · Personnel Tools			109.00
Total 10-5300 · Training			574.63
<b>10-5400 · Materials</b>			
<b>10-5410 · Books - Adult</b>			
	06/30/2022	CENTER POINT LARGE PRINT	46.74
	06/30/2022	GALE	60.78
	06/30/2022	GALE	121.56
	06/30/2022	GALE	159.14
	06/30/2022	GALE	27.99
	06/30/2022	GALE	20.79
	06/30/2022	TSAI FONG BOOKS, INC.	837.61
	06/30/2022	BAKER & TAYLOR - L5742022	457.37
	06/30/2022	BAKER & TAYLOR - L5579912	233.92
	06/30/2022	BAKER & TAYLOR - L5742022	459.25
	06/30/2022	BAKER & TAYLOR - L3966532	486.25
	06/30/2022	BAKER & TAYLOR - L5580152	270.80
	06/30/2022	BAKER & TAYLOR - L5742022	475.95
	06/30/2022	BAKER & TAYLOR - L5580072	8.28
	06/30/2022	BAKER & TAYLOR - L5742022	503.79
	06/30/2022	BAKER & TAYLOR - L5742022	444.16
	06/30/2022	BAKER & TAYLOR - C0209743	127.83
	06/30/2022	BAKER & TAYLOR - C5217413	106.93
	06/30/2022	BAKER & TAYLOR - C5217413	12.49

COOK MEMORIAL PUBLIC LIBRARY DISTRICT

**Bills Paid Report By Class**

June 18 through July 15, 2022

<u>Date</u>	<u>Name</u>	<u>Paid Amount</u>
06/30/2022	BAKER & TAYLOR - L5579912	253.80
06/30/2022	GALE	27.99
06/30/2022	GALE	149.97
06/30/2022	BAKER & TAYLOR - L5742022	289.59
06/30/2022	BAKER & TAYLOR - L5580152	350.20
06/30/2022	BAKER & TAYLOR - C5217413	47.28
06/30/2022	GALE	60.78
06/30/2022	BAKER & TAYLOR - L5742022	1,109.64
06/30/2022	BAKER & TAYLOR - L5742022	465.35
06/30/2022	BAKER & TAYLOR - L5580152	659.89
06/30/2022	BAKER & TAYLOR - C0209743	117.23
06/30/2022	BAKER & TAYLOR - C0209743	20.77
06/30/2022	BAKER & TAYLOR - L3966532	657.49
06/30/2022	BAKER & TAYLOR - L5742022	427.56
06/30/2022	GALE	425.46
06/30/2022	GALE	182.34
06/30/2022	GALE	49.49
06/30/2022	GALE	44.78
06/30/2022	GALE	50.99
06/30/2022	BAKER & TAYLOR - L5742022	1,251.26
06/30/2022	BAKER & TAYLOR - L5742022	603.02
06/30/2022	BAKER & TAYLOR - L3966532	421.74
07/15/2022	CENTER POINT LARGE PRINT	94.08
07/15/2022	THOMSON REUTERS - WEST	108.00
07/15/2022	BAKER & TAYLOR - L5580152	711.89
07/15/2022	BAKER & TAYLOR - L3966532	451.06
07/15/2022	BAKER & TAYLOR - L5579912	115.62
07/15/2022	BAKER & TAYLOR - L5580072	27.22
07/15/2022	BAKER & TAYLOR - L5580152	361.36
07/15/2022	BAKER & TAYLOR - L5742022	418.38
07/15/2022	BAKER & TAYLOR - L5742022	547.69
07/15/2022	BAKER & TAYLOR - L5742022	761.72
07/15/2022	BAKER & TAYLOR - L5579912	448.65

COOK MEMORIAL PUBLIC LIBRARY DISTRICT

**Bills Paid Report By Class**

June 18 through July 15, 2022

	<u>Date</u>	<u>Name</u>	<u>Paid Amount</u>
	07/15/2022	BAKER & TAYLOR - L5742022	695.42
	07/15/2022	BAKER & TAYLOR - L5580152	266.75
	07/15/2022	BAKER & TAYLOR - C5217413	90.58
	07/15/2022	BAKER & TAYLOR - C0209743	118.86
	07/15/2022	BAKER & TAYLOR - C0209743	24.52
	07/15/2022	BAKER & TAYLOR - C0209743	341.91
	07/15/2022	TSAI FONG BOOKS, INC.	167.12
	06/30/2022	CFRA	130.00
	06/30/2022	KLINE, SANDY	30.57
	06/30/2022	Amazon Marketplace.com - CMPL Credit Card	176.53
	06/30/2022	Amazon Marketplace.com - CMPL Credit Card	43.96
Total 10-5410 · Books - Adult			18,660.14
<b>10-5415 · Books - Juvenile</b>			
	06/30/2022	BAKER & TAYLOR - L5580072	533.68
	06/30/2022	BAKER & TAYLOR - L3966522	299.36
	06/30/2022	BAKER & TAYLOR - L4231142	386.66
	06/30/2022	BAKER & TAYLOR - L5580072	417.13
	06/30/2022	BAKER & TAYLOR - L3966522	465.94
	06/30/2022	BAKER & TAYLOR - L4231522	101.26
	06/30/2022	BAKER & TAYLOR - L4231142	264.01
	06/30/2022	BAKER & TAYLOR - L4231522	56.36
	06/30/2022	BAKER & TAYLOR - L4231142	207.10
	06/30/2022	BAKER & TAYLOR - L3966522	289.29
	06/30/2022	BAKER & TAYLOR - L5580072	295.55
	06/30/2022	BAKER & TAYLOR - L3966522	122.91
	06/30/2022	BAKER & TAYLOR - L3966522	143.65
	06/30/2022	BAKER & TAYLOR - L5580072	581.43
	06/30/2022	BAKER & TAYLOR - L5580072	1,198.75
	06/30/2022	BAKER & TAYLOR - L5580072	981.90
	07/15/2022	BAKER & TAYLOR - L5580072	299.65
	07/15/2022	BAKER & TAYLOR - L3966522	156.00
	07/15/2022	BAKER & TAYLOR - L4231522	26.10
	07/15/2022	BAKER & TAYLOR - L4231142	402.44

COOK MEMORIAL PUBLIC LIBRARY DISTRICT  
Bills Paid Report By Class

June 18 through July 15, 2022

	<u>Date</u>	<u>Name</u>	<u>Paid Amount</u>
	07/15/2022	BAKER & TAYLOR - L5580072	311.01
	07/15/2022	BAKER & TAYLOR - L4231142	321.15
	07/15/2022	BAKER & TAYLOR - L5580072	347.07
	06/30/2022	Amazon Marketplace.com - CMPL Credit Card	28.95
Total 10-5415 · Books - Juvenile			8,237.35
<b>10-5420 · Audio/Visual - Adult</b>			
	06/30/2022	MIDWEST TAPE, LLC	262.47
	06/30/2022	MIDWEST TAPE, LLC	309.84
	06/30/2022	MIDWEST TAPE, LLC	1,997.92
	06/30/2022	MIDWEST TAPE, LLC	334.50
	07/15/2022	MIDWEST TAPE, LLC	1,966.99
	07/15/2022	MIDWEST TAPE, LLC	1,696.07
	07/15/2022	MIDWEST TAPE, LLC	103.23
	06/30/2022	MIDWEST TAPE, LLC	-359.84
	06/30/2022	MIDWEST TAPE, LLC	1,847.31
	06/30/2022	Amazon Marketplace.com - CMPL Credit Card	50.47
	06/30/2022	Amazon Marketplace.com - CMPL Credit Card	11.99
Total 10-5420 · Audio/Visual - Adult			8,220.95
<b>10-5425 · Audio/Visual - Juvenile</b>			
	07/15/2022	MIDWEST TAPE, LLC	67.44
	06/30/2022	MIDWEST TAPE, LLC	88.46
Total 10-5425 · Audio/Visual - Juvenile			155.90
<b>10-5430 · Games - Adult</b>			
	06/30/2022	CRIMSON MULTIMEDIA DISTRIBUTION, INC.	120.00
	06/30/2022	CRIMSON MULTIMEDIA DISTRIBUTION, INC.	166.68
	07/15/2022	CRIMSON MULTIMEDIA DISTRIBUTION, INC.	443.44
	07/15/2022	CRIMSON MULTIMEDIA DISTRIBUTION, INC.	301.47
	07/15/2022	CRIMSON MULTIMEDIA DISTRIBUTION, INC.	311.66
Total 10-5430 · Games - Adult			1,343.25
<b>10-5435 · Games - Children</b>			
	07/15/2022	CRIMSON MULTIMEDIA DISTRIBUTION, INC.	1,341.23
	06/30/2022	Amazon Marketplace.com - CMPL Credit Card	29.90
Total 10-5435 · Games - Children			1,371.13



COOK MEMORIAL PUBLIC LIBRARY DISTRICT

**Bills Paid Report By Class**

June 18 through July 15, 2022

	<u>Date</u>	<u>Name</u>	<u>Paid Amount</u>
<b>10-5440 - Periodicals - Adult</b>			
	07/15/2022	FOREIGN AFFAIRS	39.95
	06/30/2022	BARNES & NOBLE, INC.	18.39
	06/30/2022	Pioneer Press - CMPL Credit Card	26.00
Total 10-5440 - Periodicals - Adult			<u>84.34</u>
<b>10-5450 - Circulating Technologies</b>			
<b>10-5451 - Circ Tech - Equipment</b>			
	06/30/2022	Amazon Marketplace.com - CMPL Credit Card	64.76
Total 10-5451 - Circ Tech - Equipment			<u>64.76</u>
<b>10-5453 - Circ Tech - Subscriptions</b>			
	06/30/2022	AppleTV.com - CMPLD Credit Card	4.99
	06/30/2022	HBOMAX.com - CMPL Credit Card	29.98
	06/30/2022	Hulu - CMPL Credit Card	13.98
	06/30/2022	Hulu - CMPL Credit Card	27.98
	06/30/2022	Hulu - CMPL Credit Card	12.99
	06/30/2022	Netflix.com - CMPL Credit Card	39.98
	06/30/2022	Netflix.com - CMPL Credit Card	19.99
Total 10-5453 - Circ Tech - Subscriptions			<u>149.89</u>
Total 10-5450 - Circulating Technologies			<u>214.65</u>
<b>10-5490 - Electronic Services</b>			
<b>10-5491 - Online Databases</b>			
<b>10-5492 - Online Databases - Adults</b>			
	07/15/2022	NEW YORK TIMES	2,002.00
	07/15/2022	NEWSBANK INC.	6,587.00
	07/15/2022	JOANN STORES, LLC	1,795.00
	07/15/2022	PROQUEST LLC	12,821.80
	07/15/2022	CARAHSOFT TECHNOLOGY CORP	13,125.00
	07/15/2022	PROQUEST LLC	8,961.00
Total 10-5492 - Online Databases - Adults			<u>45,291.80</u>
Total 10-5491 - Online Databases			<u>45,291.80</u>
<b>10-5494 - Digital Popular Materials</b>			
<b>10-5495 - Dig. Popular Materials - Adults</b>			
	06/30/2022	OVERDRIVE, INC.	458.02

COOK MEMORIAL PUBLIC LIBRARY DISTRICT

**Bills Paid Report By Class**

June 18 through July 15, 2022

	<u>Date</u>	<u>Name</u>	<u>Paid Amount</u>
	06/30/2022	OVERDRIVE, INC.	750.13
	06/30/2022	OVERDRIVE, INC.	401.14
	06/30/2022	OVERDRIVE, INC.	1,766.79
	06/30/2022	OVERDRIVE, INC.	344.56
	06/30/2022	OVERDRIVE, INC.	933.70
	06/30/2022	OVERDRIVE, INC.	497.67
	06/30/2022	OVERDRIVE, INC.	248.34
	06/30/2022	OVERDRIVE, INC.	851.43
	06/30/2022	OVERDRIVE, INC.	21.99
	06/30/2022	OVERDRIVE, INC.	1,014.98
	06/30/2022	OVERDRIVE, INC.	233.99
	07/15/2022	KANOPY INC.	458.00
	07/15/2022	OVERDRIVE, INC.	65.99
	07/15/2022	OVERDRIVE, INC.	202.04
	07/15/2022	OVERDRIVE, INC.	3,000.00
	07/15/2022	OVERDRIVE, INC.	9,000.00
	07/15/2022	BIBLIOTHECA, LLC	5,000.00
	07/15/2022	MIDWEST TAPE, LLC	9,199.77
	06/30/2022	BIBLIOTHECA, LLC	5,283.27
	07/15/2022	BIBLIOTHECA, LLC	136.98
			<hr/>
Total 10-5495 · Dig. Popular Materials - Adults			39,868.79
			<hr/>
Total 10-5494 · Digital Popular Materials			39,868.79
			<hr/>
Total 10-5490 · Electronic Services			85,160.59
			<hr/>
Total 10-5400 · Materials			123,448.30
			<hr/>
<b>10-5500 · Processing</b>			
<b>10-5520 · Cataloging</b>			
	07/15/2022	MIDWEST TAPE, LLC	120.00
			<hr/>
Total 10-5520 · Cataloging			120.00
			<hr/>
Total 10-5500 · Processing			120.00
			<hr/>
<b>10-5600 · Supplies</b>			
<b>10-5611 · Supplies - Admin</b>			
	06/30/2022	WAREHOUSE DIRECT OFFICE PRODUCTS, INC.	352.18
	06/30/2022	WAREHOUSE DIRECT OFFICE PRODUCTS, INC.	61.68

# COOK MEMORIAL PUBLIC LIBRARY DISTRICT

## Bills Paid Report By Class

June 18 through July 15, 2022

	<u>Date</u>	<u>Name</u>	<u>Paid Amount</u>
	06/30/2022	WAREHOUSE DIRECT OFFICE PRODUCTS, INC.	321.68
Total 10-5611 · Supplies - Admin			735.54
<b>10-5612 · Supplies - Adults</b>			
	06/30/2022	WAREHOUSE DIRECT OFFICE PRODUCTS, INC.	8.42
	06/30/2022	AMERICAN LIBRARY ASSOCIATION	79.02
	06/30/2022	AMERICAN LIBRARY ASSOCIATION	-18.00
	06/30/2022	Amazon Marketplace.com - CMPL Credit Card	12.97
Total 10-5612 · Supplies - Adults			82.41
<b>10-5613 · Supplies - Children's</b>			
	06/30/2022	EBAY - CMPL Credit Card	5.62
	06/30/2022	Amazon Marketplace.com - CMPL Credit Card	49.26
	06/30/2022	Amazon Marketplace.com - CMPL Credit Card	49.98
	06/30/2022	WAREHOUSE DIRECT OFFICE PRODUCTS, INC.	267.90
	06/30/2022	Lakeshore Learning - CMPL Credit Card	33.38
	06/30/2022	Amazon Marketplace.com - CMPL Credit Card	87.99
	06/30/2022	Wayfair.com - CMPL Credit Card	266.99
	06/30/2022	Myeblox.com - CMPL Credit Card	5.24
Total 10-5613 · Supplies - Children's			766.36
<b>10-5614 · Supplies - Circulation</b>			
	06/30/2022	WAREHOUSE DIRECT OFFICE PRODUCTS, INC.	55.76
Total 10-5614 · Supplies - Circulation			55.76
<b>10-5615 · Supplies - Maintenance</b>			
	06/30/2022	WAREHOUSE DIRECT OFFICE PRODUCTS, INC.	1,248.53
	07/15/2022	LOWE'S	11.29
	07/15/2022	ACE HARDWARE OF LIBERTYVILLE, INC.	34.54
	07/15/2022	FERGUSON ENTERPRISES, INC.	27.49
	07/15/2022	LOWE'S	10.22
	06/30/2022	Zoro.com - CMPL Credit Card	211.59
	06/30/2022	ULINE, INC	150.23
	06/30/2022	Zoro.com - CMPL Credit Card	-12.45
	06/30/2022	Lighting 2 Light - CMPL Credit Card	556.00
Total 10-5615 · Supplies - Maintenance			2,237.44
<b>10-5617 · Supplies - Outreach</b>			

COOK MEMORIAL PUBLIC LIBRARY DISTRICT

Bills Paid Report By Class

June 18 through July 15, 2022

	<u>Date</u>	<u>Name</u>	<u>Paid Amount</u>
	06/30/2022	WAREHOUSE DIRECT OFFICE PRODUCTS, INC.	28.90
Total 10-5617 · Supplies - Outreach			28.90
<b>10-5618 · Supplies - Tech Services</b>			
	06/30/2022	COMPUTYPE, INC.	3,238.50
	06/30/2022	Kapco - CMPL Credit Card	168.60
	07/15/2022	DEMCO, INC.	511.08
	06/30/2022	COMPUTYPE, INC.	820.51
	06/30/2022	DEMCO, INC.	54.11
	06/30/2022	DEMCO, INC.	108.22
Total 10-5618 · Supplies - Tech Services			4,901.02
<b>10-5660 · Supplies - Computer</b>			
	06/30/2022	Amazon Marketplace.com - CMPL Credit Card	46.99
	06/30/2022	WAREHOUSE DIRECT OFFICE PRODUCTS, INC.	4,268.09
Total 10-5660 · Supplies - Computer			4,315.08
<b>10-5680 · Supplies - Staff Room</b>			
	07/15/2022	REFRESHING GREAT LAKES, LLC	39.00
	06/30/2022	WAREHOUSE DIRECT OFFICE PRODUCTS, INC.	410.60
	07/15/2022	REFRESHING GREAT LAKES, LLC	259.40
Total 10-5680 · Supplies - Staff Room			709.00
Total 10-5600 · Supplies			13,831.51
<b>10-5700 · Vehicles</b>			
<b>10-5710 · Bookmobile Fuel</b>			
	07/15/2022	VILLAGE-VERNON	248.41
Total 10-5710 · Bookmobile Fuel			248.41
<b>10-5720 · Bookmobile Maintenance/Repair</b>			
	06/30/2022	Lake County Truck Sales-CMPL Credit Card	419.35
	06/30/2022	83RV Inc - CMPL Credit Card	121.31
Total 10-5720 · Bookmobile Maintenance/Repair			540.66
<b>10-5730 · Bookmobile Delivery Service</b>			
	06/30/2022	MACTAGGART, CONSTANCE	131.92
	07/15/2022	DITTMAN, SUSAN	35.10
Total 10-5730 · Bookmobile Delivery Service			167.02
<b>10-5750 · Van Fuel</b>			

COOK MEMORIAL PUBLIC LIBRARY DISTRICT

**Bills Paid Report By Class**

June 18 through July 15, 2022

	<u>Date</u>	<u>Name</u>	<u>Paid Amount</u>
	07/15/2022	VILLAGE-VERNON	275.88
Total 10-5750 · Van Fuel			<u>275.88</u>
Total 10-5700 · Vehicles			1,231.97
<b>10-5800 · Computer Operations</b>			
<b>10-5865 · Remote Communications Expenses</b>			
	07/15/2022	ECKMANN, ROBERT	10.00
	07/15/2022	GAFKA, DEBORAH	10.00
	07/15/2022	KRAUSE, DONNA	10.00
	07/15/2022	COMPTON, PATRICIA	10.00
	07/15/2022	DOWNS SAMUELSON, HALEY	10.00
	07/15/2022	KING, BECKY	10.00
	07/15/2022	LARSON, ANDREA	10.00
	07/15/2022	MORTON, MARK	5.00
	07/15/2022	SCHOENFIELD, SONIA	10.00
Total 10-5865 · Remote Communications Expenses			<u>85.00</u>
<b>10-5830 · Replacement Hardware/Software</b>			
<b>10-5831 · Rep Hrdwre/Sftwre - Admin</b>			
	06/30/2022	Liberated Syndication - CMPL Credit Card	15.00
	06/30/2022	Payflow/Paypal - CMPL Credit Card	30.00
	06/30/2022	Payflow/Paypal - CMPL Credit Card	0.10
	06/30/2022	Payflow/Paypal - CMPL Credit Card	0.10
	07/15/2022	RAILS	15,000.00
	06/30/2022	Amazon Marketplace.com - CMPL Credit Card	14.50
	06/30/2022	Amazon Marketplace.com - CMPL Credit Card	78.50
	06/30/2022	COMPUTER VIEW, INC.	300.00
	06/30/2022	COMPUTER VIEW, INC.	4,518.00
	06/30/2022	Timely - CMPL Credit Card	200.00
	06/30/2022	Amazon Marketplace.com - CMPL Credit Card	169.99
	07/15/2022	SIDECAR PUBLICATIONS, LLC	120.00
	07/15/2022	SIDECAR PUBLICATIONS, LLC	348.00
	06/30/2022	Olark - CMPL Credit Card	88.20
Total 10-5831 · Rep Hrdwre/Sftwre - Admin			<u>20,882.39</u>
Total 10-5830 · Replacement Hardware/Software			20,882.39

**COOK MEMORIAL PUBLIC LIBRARY DISTRICT**  
**Bills Paid Report By Class**

June 18 through July 15, 2022

	<u>Date</u>	<u>Name</u>	<u>Paid Amount</u>
<b>10-5840 · LAN Services</b>			
	06/30/2022	COMPUTER VIEW, INC.	48,200.00
Total 10-5840 · LAN Services			<u>48,200.00</u>
<b>10-5850 · Misc Contracts</b>			
	07/15/2022	ENVISIONWARE, INC.	1,450.00
Total 10-5850 · Misc Contracts			<u>1,450.00</u>
<b>10-5860 · Internet</b>			
	07/15/2022	COMCAST	921.00
Total 10-5860 · Internet			<u>921.00</u>
Total 10-5800 · Computer Operations			<u>71,538.39</u>
<b>10-5900 · Utilities</b>			
<b>10-5910 · Electricity</b>			
<b>10-5911 · Electricity - Aspen</b>			
	07/15/2022	CONSTELLATION NEW ENERGY, INC.	2,967.00
Total 10-5911 · Electricity - Aspen			<u>2,967.00</u>
<b>10-5912 · Electricity - Cook Park</b>			
	07/15/2022	CONSTELLATION NEW ENERGY, INC.	4,282.12
Total 10-5912 · Electricity - Cook Park			<u>4,282.12</u>
Total 10-5910 · Electricity			<u>7,249.12</u>
<b>10-5920 · Gas</b>			
<b>10-5921 · Gas - Aspen</b>			
	07/15/2022	CONSTELLATION NATURAL GAS	299.29
Total 10-5921 · Gas - Aspen			<u>299.29</u>
<b>10-5922 · Gas - Cook Park</b>			
	07/15/2022	CONSTELLATION NATURAL GAS	490.65
Total 10-5922 · Gas - Cook Park			<u>490.65</u>
Total 10-5920 · Gas			<u>789.94</u>
<b>10-5930 · Water</b>			
<b>10-5932 · Water - Cook Park</b>			
	07/15/2022	VILLAGE-LIBERTYVILLE	858.32
Total 10-5932 · Water - Cook Park			<u>858.32</u>
Total 10-5930 · Water			<u>858.32</u>

COOK MEMORIAL PUBLIC LIBRARY DISTRICT

**Bills Paid Report By Class**

June 18 through July 15, 2022

	<u>Date</u>	<u>Name</u>	<u>Paid Amount</u>
Total 10-5900 · Utilities			8,897.38
<b>10-6000 · Telephone</b>			
<b>10-6010 · Telephone</b>			
	06/30/2022	COMCAST	295.89
	07/15/2022	PEERLESS NETWORK, INC.	1,107.89
Total 10-6010 · Telephone			1,403.78
<b>10-6020 · Bookmobile - Telephone</b>			
	06/30/2022	VERIZON WIRELESS SERVICES LLC	230.43
Total 10-6020 · Bookmobile - Telephone			230.43
<b>10-6050 · Telephone Service Contracts</b>			
	06/30/2022	BLUE WIRE COMMUNICATIONS	1,495.74
Total 10-6050 · Telephone Service Contracts			1,495.74
Total 10-6000 · Telephone			3,129.95
<b>10-6100 · Postage</b>			
	07/15/2022	PITNEY BOWES - RESERVE ACCOUNT	1,000.00
Total 10-6100 · Postage			1,000.00
<b>10-6200 · Maintenance</b>			
<b>10-6210 · Janitorial Service</b>			
<b>10-6211 · Janitorial Service - Aspen</b>			
	07/15/2022	COMPLETE CLEANING COMPANY, INC.	2,381.83
Total 10-6211 · Janitorial Service - Aspen			2,381.83
<b>10-6212 · Janitorial Service - Cook Park</b>			
	07/15/2022	COMPLETE CLEANING COMPANY, INC.	3,818.89
Total 10-6212 · Janitorial Service - Cook Park			3,818.89
Total 10-6210 · Janitorial Service			6,200.72
<b>10-6220 · Landscaping Service</b>			
<b>10-6221 · Landscaping - Aspen</b>			
	07/15/2022	LANDSCAPE CONCEPTS, INC.	773.87
Total 10-6221 · Landscaping - Aspen			773.87
<b>10-6222 · Landscaping - Cook Park</b>			
	07/15/2022	LANDSCAPE CONCEPTS, INC.	517.12
Total 10-6222 · Landscaping - Cook Park			517.12

**COOK MEMORIAL PUBLIC LIBRARY DISTRICT**  
**Bills Paid Report By Class**

June 18 through July 15, 2022

	<u>Date</u>	<u>Name</u>	<u>Paid Amount</u>
Total 10-6220 · Landscaping Service			1,290.99
<b>10-6230 · Snow Removal</b>			
<b>10-6231 · Snow Removal - Aspen</b>			
	06/30/2022	JAMES MARTIN ASSOCIATES, INC.	462.00
Total 10-6231 · Snow Removal - Aspen			462.00
Total 10-6230 · Snow Removal			462.00
<b>10-6240 · Trash Removal</b>			
<b>10-6242 · Trash Removal - Cook Park</b>			
	06/30/2022	GROOT INDUSTRIES, INC.	228.55
Total 10-6242 · Trash Removal - Cook Park			228.55
Total 10-6240 · Trash Removal			228.55
<b>10-6250 · Miscellaneous</b>			
<b>10-6251 · Misc. Maintenance - Aspen</b>			
	07/15/2022	AMS OF NORTHERN ILLINOIS	198.00
	07/15/2022	ANDERSON PEST SOLUTIONS	93.40
Total 10-6251 · Misc. Maintenance - Aspen			291.40
<b>10-6252 · Misc. Maintenance - Cook Park</b>			
	06/30/2022	IRON MOUNTAIN INCORPORATED	101.16
	07/15/2022	AMS OF NORTHERN ILLINOIS	149.00
	07/15/2022	AMBIUS, LLC (19)	347.98
Total 10-6252 · Misc. Maintenance - Cook Park			598.14
Total 10-6250 · Miscellaneous			889.54
Total 10-6200 · Maintenance			9,071.80
<b>10-6300 · Repair</b>			
<b>10-6320 · Building &amp; Grounds Repairs</b>			
<b>10-6321 · Building Repairs - Aspen</b>			
	07/15/2022	DE MARR SEALCOATING, INC.	9,170.00
	06/30/2022	TEE JAY SERVICE COMPANY, INC.	316.00
Total 10-6321 · Building Repairs - Aspen			9,486.00
Total 10-6320 · Building & Grounds Repairs			9,486.00
<b>10-6340 · Service Contracts-Mech. &amp; Bldg.</b>			
<b>10-6341 · Service Contracts - Aspen</b>			



COOK MEMORIAL PUBLIC LIBRARY DISTRICT

Bills Paid Report By Class

June 18 through July 15, 2022

	<u>Date</u>	<u>Name</u>	<u>Paid Amount</u>
	06/30/2022	AMERICAN BACKFLOW PREVENTION, INC.	550.00
Total 10-6341 · Service Contracts - Aspen			550.00
<b>10-6342 · Service Contracts - Cook Park</b>			
	06/30/2022	FIRE & SECURITY SERVICES, INC.	147.00
	06/30/2022	AMERICAN BACKFLOW PREVENTION, INC.	595.00
Total 10-6342 · Service Contracts - Cook Park			742.00
Total 10-6340 · Service Contracts-Mech. & Bldg.			1,292.00
Total 10-6300 · Repair			10,778.00
<b>10-6500 · Professional Services</b>			
<b>10-6540 · Payroll Processing</b>			
	06/30/2022		399.13
	07/15/2022		1,027.84
Total 10-6540 · Payroll Processing			1,426.97
<b>10-6575 · Miscellaneous Services &amp; Fees</b>			
	06/30/2022		20.00
Total 10-6575 · Miscellaneous Services & Fees			20.00
Total 10-6500 · Professional Services			1,446.97
<b>10-6600 · Improvements</b>			
<b>10-6630 · Equipment</b>			
<b>10-6631 · Equipment - Admin</b>			
	06/30/2022	Oransi - CMPL Credit Card	1,596.04
Total 10-6631 · Equipment - Admin			1,596.04
Total 10-6630 · Equipment			1,596.04
<b>10-6650 · Copiers &amp; Other Leased Equip</b>			
	07/15/2022	PITNEY BOWES GLOBAL FINANCIAL SERVICES	504.72
Total 10-6650 · Copiers & Other Leased Equip			504.72
Total 10-6600 · Improvements			2,100.76
<b>10-6700 · Community Relations</b>			
<b>10-6712 · Graphics</b>			
	06/30/2022	ADOBE - CMPL Credit Card	29.99
Total 10-6712 · Graphics			29.99
<b>10-6720 · Programming - Adult</b>			

COOK MEMORIAL PUBLIC LIBRARY DISTRICT  
Bills Paid Report By Class

June 18 through July 15, 2022

	<u>Date</u>	<u>Name</u>	<u>Paid Amount</u>
<b>10-6721 · Programs - Performances</b>			
	07/15/2022	GRINNELL, MAX	400.00
	06/30/2022	WOOD, BARRY	90.00
	06/30/2022	MADDOX, SUSAN K.	400.00
	06/30/2022	ANTONIO, LUCIANO	1,000.00
	06/22/2022	AMERICAN ENGLISH	2,500.00
	06/30/2022	AMERICAN ENGLISH	2,500.00
	07/15/2022	GARY E. MIDKIFF & COMPANY	210.00
	06/30/2022	ZOLTOWSKY, JULIA	125.00
	07/15/2022	NACHAMIE, STEPHEN	250.00
	06/30/2022	OPSAL, CAROL	50.00
	07/15/2022	OPSAL, CAROL	50.00
	06/30/2022	SECOND HAND SOUL BAND INC	900.00
	06/30/2022	VIGNETO del BINO, INC.	538.50
	07/15/2022	MADDOX, COLBY	500.00
	06/22/2022	MADDOX, COLBY	500.00
	06/30/2022	SWANK MOVIE LICENSING USA	236.00
Total 10-6721 · Programs - Performances			10,249.50
<b>10-6726 · Computer</b>			
	06/30/2022	MONTANO, ESTEVAN	150.00
	07/15/2022	MONTANO, ESTEVAN	150.00
	07/15/2022	MONTANO, ESTEVAN	150.00
	07/15/2022	MAYBERRY, MELISSA	150.00
	06/30/2022	MONTANO, ESTEVAN	150.00
	06/30/2022	MONTANO, ESTEVAN	150.00
	06/30/2022	MAYBERRY, MELISSA	150.00
	06/28/2022	MAYBERRY, MELISSA	-150.00
	07/15/2022	MONTANO, ESTEVAN	150.00
Total 10-6726 · Computer			1,050.00
Total 10-6720 · Programming - Adult			11,299.50
<b>10-6730 · Programming - Young Adult</b>			
<b>10-6731 · Programs - YA (Other)</b>			
	06/30/2022	MORTON, MARK	42.66

COOK MEMORIAL PUBLIC LIBRARY DISTRICT

Bills Paid Report By Class

June 18 through July 15, 2022

	<u>Date</u>	<u>Name</u>	<u>Paid Amount</u>
Total 10-6731 · Programs - YA (Other)			42.66
Total 10-6730 · Programming - Young Adult			42.66
<b>10-6740 · Programming - Children's</b>			
	07/15/2022	JENSEN, JENNIFER	95.28
	06/30/2022	BHATTACHARYA, RACHANA	250.00
	06/30/2022	BEVERLEY, JOEL	150.00
	06/30/2022	Amazon Marketplace.com - CMPL Credit Card	163.25
	06/30/2022	Amazon Marketplace.com - CMPL Credit Card	7.99
	06/30/2022	Amazon Marketplace.com - CMPL Credit Card	34.44
	06/30/2022	Amazon Marketplace.com - CMPL Credit Card	9.25
	06/30/2022	Amazon Marketplace.com - CMPL Credit Card	-12.60
	07/15/2022	RAINBOW ASSISTED	200.00
	06/30/2022	Amazon Marketplace.com - CMPL Credit Card	23.25
	07/15/2022	FROGLADY PRESENTATIONS	400.00
	07/15/2022	ANDERSON, MARK	300.00
	07/15/2022	VRABLIK II, SCOTT STEVEN	215.00
	06/30/2022	Amazon Marketplace.com - CMPL Credit Card	33.85
	06/30/2022	Amazon Marketplace.com - CMPL Credit Card	29.38
	06/30/2022	Amazon Marketplace.com - CMPL Credit Card	4.99
	06/30/2022	Amazon Marketplace.com - CMPL Credit Card	8.10
	06/30/2022	Amazon Marketplace.com - CMPL Credit Card	12.99
	06/30/2022	Amazon Marketplace.com - CMPL Credit Card	21.87
	06/30/2022	Oriental Trading Co - CMPL Credit Card	31.98
	07/15/2022	GADDAM, SRIHARI	400.00
	06/30/2022	SAM'S CLUB DIRECT	133.76
	06/30/2022	Smilemakers - CMPL Credit Card	81.06
	06/30/2022	Amazon Marketplace.com - CMPL Credit Card	12.60
	06/30/2022	Amazon Marketplace.com - CMPL Credit Card	16.94
	06/30/2022	Joann Fabrics - CMPL Credit Card	22.90
Total 10-6740 · Programming - Children's			2,646.28
<b>10-6750 · Printing</b>			
<b>10-6752 · Printing - Children's</b>			
	06/30/2022	Fedex Office - CMPL Credit Card	564.15

COOK MEMORIAL PUBLIC LIBRARY DISTRICT

Bills Paid Report By Class

June 18 through July 15, 2022

	<u>Date</u>	<u>Name</u>	<u>Paid Amount</u>
Total 10-6752 · Printing - Children's			564.15
Total 10-6750 · Printing			564.15
<b>10-6760 · Promotions/Prizes</b>			
<b>10-6761 · Promotions/Prizes- Admin/Gen</b>			
	06/30/2022	LazyDogRestaurants.com - CMPL Credit Card	100.00
	06/30/2022	Yiftee.com - CMPLD Credit Card	106.00
	06/30/2022	Target Store - CMPL Credit Card	100.00
	06/30/2022	OfficeDepot/OfficeMax - CMPL Credit Card	63.94
Total 10-6761 · Promotions/Prizes- Admin/Gen			369.94
<b>10-6763 · Promotions/Prizes - Children's</b>			
	07/15/2022	ECO PROMOTIONAL PRODUCTS, INC.	1,178.44
	07/15/2022	BAKER & TAYLOR - L5588902	47.74
	06/30/2022	BAKER & TAYLOR - L5588902	52.66
Total 10-6763 · Promotions/Prizes - Children's			1,278.84
Total 10-6760 · Promotions/Prizes			1,648.78
<b>10-6780 · Digital Studios</b>			
<b>10-6781 · Digital Studios - Equipment</b>			
	06/30/2022	Amazon Marketplace.com - CMPL Credit Card	32.98
	06/30/2022	Amazon Marketplace.com - CMPL Credit Card	129.99
	06/30/2022	Amazon Marketplace.com - CMPL Credit Card	12.98
	06/30/2022	Amazon Marketplace.com - CMPL Credit Card	1,007.58
Total 10-6781 · Digital Studios - Equipment			1,183.53
Total 10-6780 · Digital Studios			1,183.53
<b>10-6790 · Workshops</b>			
<b>10-6792 · Workshops - Software</b>			
	06/30/2022	American Button Machines-CMPL Credit Card	172.95
Total 10-6792 · Workshops - Software			172.95
<b>10-6793 · Workshops - Programs/Classes</b>			
	06/30/2022	Amazon Marketplace.com - CMPL Credit Card	12.98
	06/30/2022	Amazon Marketplace.com - CMPL Credit Card	85.22
	06/30/2022	Amazon Marketplace.com - CMPL Credit Card	7.47
	06/30/2022	Amazon Marketplace.com - CMPL Credit Card	3.96
	06/30/2022	Amazon Marketplace.com - CMPL Credit Card	28.14

COOK MEMORIAL PUBLIC LIBRARY DISTRICT  
Bills Paid Report By Class

June 18 through July 15, 2022

	Date	Name	Paid Amount
Total 10-6793 · Workshops - Programs/Classes			137.77
<b>10-6794 · Workshops - Supplies</b>			
	06/30/2022	American Button Machines-CMPL Credit Card	128.15
Total 10-6794 · Workshops - Supplies			128.15
Total 10-6790 · Workshops			438.87
Total 10-6700 · Community Relations			17,853.76
<b>10-7000 · Debt Service</b>			
	07/15/2022	CHASE	19,947.69
	07/15/2022	CHASE	29,015.27
	07/15/2022	CAPITAL ONE PUBLIC FUNDING	77,630.90
Total 10-7000 · Debt Service			126,593.86
<b>20-8210 · Employer IMRF Disbursements</b>			
	07/01/2022		16,036.46
	07/15/2022		15,911.27
Total 20-8210 · Employer IMRF Disbursements			31,947.73
<b>20-8250 · Employer Soc Security Tax Disb</b>			
	07/01/2022		13,686.60
	07/15/2022		13,532.22
Total 20-8250 · Employer Soc Security Tax Disb			27,218.82
Total Expense			864,943.81
Net Ordinary Income			-812,037.03
<b>Other Income/Expense</b>			
<b>Other Expense</b>			
<b>60-9800 · Special Reserve Disbursements</b>			
<b>60-9809 · Aspen - Paver/Front Entrance</b>			
	07/15/2022	FEATHERSTONE, INC.	903.60
Total 60-9809 · Aspen - Paver/Front Entrance			903.60
<b>60-9813 · Cook Park - Window Replacement</b>			
	07/15/2022	FEATHERSTONE, INC.	1,600.86
Total 60-9813 · Cook Park - Window Replacement			1,600.86
Total 60-9800 · Special Reserve Disbursements			2,504.46
Total Other Expense			2,504.46

COOK MEMORIAL PUBLIC LIBRARY DISTRICT

**Bills Paid Report By Class**

June 18 through July 15, 2022

	<u>Date</u>	<u>Name</u>	<u>Paid Amount</u>
Net Other Income			-2,504.46
<b>Net Income</b>			<b><u>-814,541.49</u></b>



**Cook Memorial Public Library District**  
**Librarian's Statistical Report - Page 1**  
**June 2022**

### Registered Card Holders

The number of card holders. Excludes in-house patrons. According to the 2020 census, district population was 61,297. Accounts inactive for three years are deleted in June and December.

	June 2021			June 2022			Percent Change
	Juvenile	Adult	Total	Juvenile	Adult	Total	
Cook Memorial Public Library District	7,657	29,984	37,641	7,200	31,031	38,231	1.57%
Reciprocal Borrowing Patrons	405	5,560	5,965	394	5,525	5,919	-0.77%
<b>Total</b>	<b>8,062</b>	<b>35,544</b>	<b>43,606</b>	<b>7,594</b>	<b>36,556</b>	<b>44,150</b>	<b>1.25%</b>

### Visitors

	June 2021	June 2022	Percent Change	FY 2021 To Date	FY 2022 To Date	Percent Change
	Aspen Drive Library	9,641	12,057	25.06%	67,598	136,321
Drive-Up		407			4,085	
Cook Park Library	13,225	18,841	42.47%	86,313	155,941	80.67%
Drive-Up	1,546	1,307	-15.46%	16,266	16,525	1.59%
Outreach	135	757	460.74%	1,166	6,870	489.19%
<b>Total</b>	<b>24,547</b>	<b>33,369</b>	<b>35.94%</b>	<b>171,343</b>	<b>319,742</b>	<b>86.61%</b>

### Program Attendance

	June 2021	June 2022	Percent Change	FY 2021 To Date	FY 2022 To Date	Percent Change
	Adult	878	906	3.19%	16,494	12,930
Juvenile	1,077	1,912	77.53%	14,464	13,545	-6.35%
Young Adult	2	81	3950.00%	170	508	198.82%
	1,957	2,899	48.13%	31,128	26,983	-13.32%

### Special Services

	June 2021	June 2022	Percent Change	FY 2021 To Date	FY 2022 To Date	Percent Change
	Reference Questions	5,594	7,251	29.62%	47,995	61,951
Library App Users	340	619	82.06%	2,291	6,278	174.03%
Online Databases*	2,476	2,657	7.31%	45,753	45,574	-0.39%
www.cooklib.org	88,900	125,079	40.70%	1,066,161	1,073,166	0.66%
Holds Placed	14,812	14,361	-3.04%	224,050	169,864	-24.18%
Holds Filled	13,258	12,239	-7.69%	221,636	149,796	-32.41%
Homebound Items Delivered	460	689	49.78%	9,937	9,229	-7.12%

\*A count of sessions, available for 67 of 81 Online Databases.

### Collection Size

	June 2021				June 2022						
	Juvenile	Adult	Other	Total	Percent of Total	Juvenile	Adult	Other	Total	Percent of Total	Percent Change
Aspen Drive Library	48,667	41,931		90,598	33.35%	49,951	43,067		93,018	33.86%	2.67%
Cook Park Library	56,971	108,368	139	165,478	60.91%	57,610	107,939	143	165,692	60.32%	0.13%
Outreach	12,651	2,918	13	15,582	5.74%	12,819	3,147	13	15,979	5.82%	2.55%
<b>Total</b>	<b>118,289</b>	<b>153,217</b>	<b>152</b>	<b>271,658</b>		<b>120,380</b>	<b>154,153</b>	<b>156</b>	<b>274,689</b>		<b>1.12%</b>

## Librarian's Statistical Report - June 2022 - Page 2

### Circulation

	June 2021				June 2022				Percent Change
	Adult	Juvenile	Other	Total	Adult	Juvenile	Other	Total	
Fiction	11,902	23,847		35,749	11,874	25,401		37,275	4.27%
Foreign Language	191	232		423	264	189		453	7.09%
Large Type	1,474	36		1,510	1,466	16		1,482	-1.85%
Nonfiction	6,856	5,942		12,798	6,837	5,273		12,110	-5.38%
Periodicals	1,371	181		1,552	1,105	161		1,266	-18.43%
<b>Subtotal Print</b>	<b>21,794</b>	<b>30,238</b>		<b>52,032</b>	<b>21,546</b>	<b>31,040</b>		<b>52,586</b>	<b>1.06%</b>
Bags and Containers			11	11			10	10	-9.09%
Equipment	125	4		129	135	5		140	8.53%
Interlibrary Loan			108	108			142	142	31.48%
LINKin	1,038			1,038	996			996	-4.05%
Multimedia		112		112		429		429	283.04%
Other			16	16			5	5	-68.75%
<b>Subtotal Other</b>	<b>1,163</b>	<b>116</b>	<b>135</b>	<b>1,414</b>	<b>1,131</b>	<b>434</b>	<b>157</b>	<b>1,722</b>	<b>21.78%</b>
eAudiobooks			4,777	4,777			5,307	5,307	11.09%
eBooks			7,292	7,292			7,315	7,315	0.32%
eMagazines			751	751			304	304	-59.52%
eMusic			259	259			240	240	-7.34%
eVideo			1,132	1,132			926	926	-18.20%
<b>Subtotal Downloadables</b>			<b>14,211</b>	<b>14,211</b>			<b>14,092</b>	<b>14,092</b>	<b>-0.84%</b>
Audiobooks	613	591		1,204	640	496		1,136	-5.65%
Compact Discs	1,431	348		1,779	1,206	368		1,574	-11.52%
DVDs, Blu-Ray	9,825	3,775		13,600	8,293	3,271		11,564	-14.97%
Video Games	481	1,023		1,504	503	837		1,340	-10.90%
<b>Subtotal Audiovisual</b>	<b>12,350</b>	<b>5,737</b>		<b>18,087</b>	<b>10,642</b>	<b>4,972</b>		<b>15,614</b>	<b>-13.67%</b>
<b>Grand Total All Agencies</b>	<b>35,307</b>	<b>36,091</b>	<b>14,346</b>	<b>85,744</b>	<b>33,319</b>	<b>36,446</b>	<b>14,249</b>	<b>84,014</b>	<b>-2.02%</b>

### Agency Subtotals

	June 2021	June 2022	Percent Change	FY 2021 To Date	FY 2022 To Date	Percent Change
Downloadables	14,211	14,092	-0.84%	187,643	163,922	-12.64%
Aspen Drive Library	22,114	21,178	-4.23%	188,761	218,924	15.98%
Cook Park Library	47,221	45,749	-3.12%	465,574	506,483	8.79%
Outreach	2,198	2,995	36.26%	26,297	40,063	52.35%
<b>Total</b>	<b>85,744</b>	<b>84,014</b>	<b>-2.02%</b>	<b>868,275</b>	<b>929,392</b>	<b>7.04%</b>





## Director's Narrative Report July 2022

---

David Archer, Library Director

### **Early Childhood Learning Opportunities**

Children's Librarian Cherilyn Contreras has been accepted into a professional development program offered by the Erikson Institute, focusing on media literacy in early childhood. The program takes place online and consists of webinars and small group meetings over the course of several months. Cherilyn will be part of a cohort of about 20 youth library staff from all over the country.

Participants will learn about how young children use and comprehend various media including digital and print media. Participants will also explore strategies, practices, activities, and tools for implementing media literacy education within a library setting.

The program is funded through the Institute of Museum and Library Services, an independent federal agency that provides library grants, museum grants, policy development, and research.

Early Learning Services Supervisor / Children's Librarian Terri Norstrom recently completed a graduate certificate in Child Development from Erikson. The certificate prepares children's librarians to support a child's optimal development pathway, and to respond effectively to the needs, challenges, and strengths of young children and their families.

Early learning services is a key service of the Library, aimed to engage children and their families about our valuable services and collections.

### **4EVER4: Beatles Photo Exhibit**

From July 16-24, the Workshop at Aspen Drive is hosting 4EVER4, a photo exhibition featuring nearly 100 photographs of the Beatles from 1962-1970. The exhibit is open during library hours and presented by Republic Bank of Chicago with no direct expenses incurred by the Library. The Aspen Workshop is an ideal location for the exhibit as it is a highly visible, dedicated space that is not used heavily in the summer months.

As a companion event to the exhibit, the Friends of the Library sponsored the Beatles tribute band, American English, on July 8 at the Vernon Hills Park District's Sullivan Center, adjacent to the Aspen Drive Library. Nearly 200 attended the performance as the band played early Beatles (1962-66) and the psychedelic phase (1967-69) complete with costume changes. Many thanks to Republic Bank of Chicago and our partners at the Vernon Hills Park District for their support of the Library.

### **Outreach News**

- The Bookmobile was part of the Vernon Hills Independence Day Parade. It will also make appearances in August at the Vernon Hills National Night Out celebration and the Vernon Hills Public Works Open House.
- The Bookmobile successfully completed a 4-week visit with District 70 Summer School, serving 250 students and teachers from grades K-8.

- The Outreach department has started a partnership with Mobile Therapy Centers of America, LLC in Libertyville. The multidisciplinary therapy group provides services to children with Autism Spectrum Disorder, speech and language delays, as well as occupational and behavioral therapy. Our Bookmobile visits once a month and we deliver a set of themed books weekly. The clinic director Jill M. Grass wrote, "Please know that you are reaching children that may not normally get access to a library, so that is amazing."

### **Odds & Ends**

- The fall edition of the quarterly newsletter was delivered to 21,000 district mailboxes on August 13.
- Aspen Drive Library parking lot was sealcoated and striped in early July. This preventative maintenance is scheduled for next summer at Cook Park.
- Our popular 'Lucy Booth' has been staffed at the weekly Farmer's Market in Cook Park. Visitors can get reading recommendations and learn more about library services and programs. A story time is also held in the shade next to the library.



Cook Memorial Public Library District													
Investment Maturity Schedule													
June 30, 2022													
Investment Account	Issue Date	Maturity Date	Face Value	Coupon/YTM	Q3 2022	Q4 2022	Q1 2023	Q2 2023	Q3 2023	Q4 2023	Q1 2024	Q2 2024	Total
<b>Special Reserve Fund:</b>													
Flagstar BK FSB Troy, MI CD	16-Jun-2021	16-Jun-2023	245,000	0.150%				245,000					245,000
Goldman Sachs BK USA New York, NY CD	16-Aug-2021	17-Feb-2023	125,000	0.200%			125,000						125,000
BMW BK North Amer Salt Lake City UT CD (10/08/21)	1-Oct-2021	10-Oct-2023	245,000	0.350%						245,000			245,000
GE Cap Retail BK Draper UT CD (10/08/21)	1-Oct-2021	10-Oct-2023	245,000	0.400%						245,000			245,000
Israel Disc BK New York NY CD (11/12/21)	3-Nov-2021	14-Aug-2023	245,000	0.450%					245,000				245,000
Discover BK Greenwood DE CD (05/18/22)	11-May-2022	18-May-2023	245,000	1.950%				245,000					245,000
Ally BK Midvale UT CD (05/19/22)	11-May-2022	20-May-2024	245,000	2.950%								245,000	245,000
<b>Total Special Reserve</b>			1,595,000		-	-	125,000	490,000	245,000	490,000	-	245,000	1,595,000
<b>Working Cash Fund:</b>													
<b>Total Working Cash Fund</b>			0		-	-	-	-	-	-	-	-	-
<b>General Fund:</b>													
State BK India New York, NY CD	16-Aug-2021	16-Aug-2022	125,000	0.150%	125,000								125,000
Bank of China New York NY CD (05/18/22)	11-May-2022	21-Feb-2023	245,000	1.550%			245,000						245,000
Sandy Spring BK Olney MD CD (05/18/22)	11-May-2022	20-Nov-2023	245,000	2.350%					245,000				245,000
BMO Harris BK Natl Assn CD (06/10/22)	7-Jun-2022	11-Dec-2023	245,000	2.500%					245,000				
<b>Total General Fund</b>			860,000		125,000	-	245,000	-	-	490,000	-	-	860,000
<b>Total Investments</b>			2,455,000		125,000	-	370,000	490,000	245,000	980,000	-	245,000	2,455,000
<b>Difference</b>			0										

Cook Memorial Public Library District															
Investment Transaction Schedule - JP Morgan Chase															
Date	Investment	Transaction Type	Description	Certificates of Deposit				Savings Accounts			Interest Income				
				General Fund	Special Reserve Fund	Working Cash Fund	Total	General Fund	Special Reserve Fund	Total	CD's - General Fund	CD's - Special Reserve Fund	Savings - General Fund	Savings - Special Reserve Fund	Total
<b>31-Mar-2022</b>	<b>Ending Balance</b>			<b>370,000.00</b>	<b>1,105,000.00</b>	<b>0.00</b>	<b>1,475,000.00</b>	<b>56,471.96</b>	<b>201,043.22</b>	<b>357,504.68</b>	<b>183.26</b>	<b>310.28</b>	<b>21.04</b>	<b>74.80</b>	<b>589.38</b>
8-Apr-2022	GE Cap Retail BK Draper UT CD	Interest					0.00					488.66			488.66
8-Apr-2022	BMW BK North Amer Salt Lake City UT CD	Interest					0.00					427.58			427.58
18-Apr-2022	UBS Bk USA Salt Lake City UT CD	Interest					0.00				20.81				20.81
29-Apr-2022	Chase Bank	Interest					0.00	2.23	7.93	10.16			2.23	7.93	10.16
<b>30-Apr-2022</b>	<b>Ending Balance</b>			<b>370,000.00</b>	<b>1,105,000.00</b>	<b>0.00</b>	<b>1,475,000.00</b>	<b>56,474.19</b>	<b>201,051.15</b>	<b>357,514.84</b>	<b>204.07</b>	<b>1,226.52</b>	<b>23.27</b>	<b>82.73</b>	<b>1,536.59</b>
11-May-2022	Bank of China BK New York NY CD (05/18/22)	Purchase	1.550% - Due 02/21/23	245,000.00			245,000.00								0.00
11-May-2022	Sandy Spring BK Olney MD CD (05/18/22)	Purchase	2.350% - Due 11/20/23	245,000.00			245,000.00								0.00
16-May-2022	UBS Bk USA Salt Lake City UT CD	Interest					0.00				20.14				20.14
11-May-2022	Discover BK Greenwood DE CD (05/18/22)	Purchase	1.95% - Due 05/18/23		245,000.00		245,000.00								0.00
11-May-2022	Ally BK Midvale UT CD (05/19/22)	Purchase	2.95% - Due 05/20/24		245,000.00		245,000.00								0.00
12-May-2022	Israel Disc Bk New York NY	Interest					0.00					546.72			546.72
31-May-2022	Chase Bank	Interest					0.00	2.46	8.75	11.21			2.46	8.75	11.21
<b>31-May-2022</b>	<b>Ending Balance</b>			<b>860,000.00</b>	<b>1,595,000.00</b>	<b>0.00</b>	<b>2,455,000.00</b>	<b>56,476.65</b>	<b>201,059.90</b>	<b>357,526.05</b>	<b>224.21</b>	<b>1,773.24</b>	<b>25.73</b>	<b>91.48</b>	<b>2,114.66</b>
7-Jun-2022	BMO Harris BK Natl Assn CD (06/10/22)	Purchase	2.5% - Due 12/11/23	245,000.00			245,000.00								0.00
16-Jun-2022	UBS Bk USA Salt Lake City UT CD	Maturity		(245,000.00)			(245,000.00)								0.00
17-Jun-2022	UBS Bk USA Salt Lake City UT CD	Interest					0.00				20.81				20.81
16-Jun-2022	Flagstar BK FSB Troy MI CD	Interest					0.00					183.25			183.25
30-Jun-2022	Chase Bank	Interest					0.00	2.30	8.20	10.50			2.30	8.20	10.50
<b>30-Jun-2022</b>	<b>Ending Balance</b>			<b>860,000.00</b>	<b>1,595,000.00</b>	<b>0.00</b>	<b>2,455,000.00</b>	<b>56,478.95</b>	<b>201,068.10</b>	<b>357,536.55</b>	<b>245.02</b>	<b>1,956.49</b>	<b>28.03</b>	<b>99.68</b>	<b>2,329.22</b>

# Position Summary

49

Cook Memorial Public Library

Report date as of Jun 30, 2022

Report run time: July 04, 2022 02:32 PM

Qty	Security	Mat/Exp Date	Cost	Share Price	Market Value	Unreal G/L	% Unreal G/L	Est Ann Inc		Div/Int Rate
								Accr Inc	CY Cost Yld	
... 6412 / Cook Memorial PLD General			860,000.00		854,331	-5,669	-0.66	15,869.00	1.86	
								1,624.63	1.85	
<b>CORPORATE BONDS</b>			<b>490,000.00</b>		<b>485,772</b>	<b>-4,228</b>	<b>-0.86</b>	<b>11,883.00</b>	<b>2.45</b>	
								<b>1,013.90</b>	<b>2.43</b>	
245,000	BMO HARRIS BK NATL ASSN C/D FDIC INS TO LIMITS 05600XFR6060	2023-12-11	245,000.00	99.2070	243,057	-1,943	-0.79	6,125.00	2.52	2.50
								335.62	2.50	
245,000	SANDY SPRING BK OLNEY MD CD C/D FDIC INS TO LIMITS 800364EC1060	2023-11-20	245,000.00	99.0675	242,715	-2,285	-0.93	5,758.00	2.37	2.35
								678.28	2.35	
<b>CASH BALANCE</b>			<b>370,000.00</b>		<b>368,559</b>	<b>-1,441</b>	<b>-0.39</b>	<b>3,986.00</b>	<b>1.08</b>	
								<b>610.73</b>	<b>1.08</b>	
245,000	BANK OF CHINA NEW YORK CITY C/D FDIC INS TO LIMITS 06428FYA9060	2023-02-21	245,000.00	99.5189	243,821	-1,179	-0.48	3,798.00	1.56	1.55
								447.38	1.55	
125,000	STATE BK INDIA NEW YORK N Y C/D FDIC INS TO LIMITS 856285WT4060	2022-08-16	125,000.00	99.7904	124,738	-262	-0.21	188.00	0.15	0.15
								163.36	0.15	
... 6414 / Cook Memorial PLD Special Res			1,595,000.00		1,561,591	-33,409	-2.09	15,565.00	1.00	
								2,064.84	0.98	
<b>CORPORATE BONDS</b>			<b>1,350,000.00</b>		<b>1,318,125</b>	<b>-31,875</b>	<b>-2.36</b>	<b>10,787.00</b>	<b>0.82</b>	
								<b>1,502.01</b>	<b>0.80</b>	
245,000	ALLY BK MIDVALE UTAH C/D FDIC INS TO LIMITS 02007GRG0060	2024-05-20	245,000.00	99.4477	243,647	-1,353	-0.55	7,228.00	2.97	2.95
								831.66	2.95	
245,000	BMW BK NORTH AMER SALT LAKE CITY UTAH C/D FDIC INS TO 05580AE59060	2023-10-10	245,000.00	96.7042	236,925	-8,075	-3.30	858.00	0.36	0.35
								194.99	0.35	

J.P.Morgan

Please note disclosures and glossary included herein for important information about this report

# Position Summary

50

Cook Memorial Public Library

Report date as of Jun 30, 2022

Report run time: July 04, 2022 02:32 PM

Qty	Security	Mat/Exp Date	Cost	Share Price	Market Value	Unreal G/L	% Unreal G/L	Est Ann Inc		Div/Int Rate
								Accr Inc	CY Cost Yld	
245,000	FLAGSTAR BK FSB TROY MICH C/D FDIC INS TO LIMITS 33847E4M6060	2023-06-16	245,000.00	97.4843	238,837	-6,163	-2.52	368.00 14.09	0.15 0.15	0.15
125,000	GOLDMAN SACHS BK USA NEW YORK C/D FDIC INS TO LIMITS 38149MYJ6060	2023-02-17	125,000.00	98.6791	123,349	-1,651	-1.32	250.00 90.41	0.20 0.20	0.20
245,000	ISRAEL DISC BK NEW YORK N Y C/D FDIC INS TO LIMITS 465076SV0060	2023-08-14	245,000.00	97.2610	238,289	-6,711	-2.74	1,103.00 148.01	0.46 0.45	0.45
245,000	GE CAP RETAIL BK DRAPER UTAH C/D FDIC INS TO LIMITS 87165EUT2060	2023-10-10	245,000.00	96.7666	237,078	-7,922	-3.23	980.00 222.85	0.41 0.40	0.40
<b>CASH BALANCE</b>			<b>245,000.00</b>		<b>243,466</b>	<b>-1,534</b>	<b>-0.63</b>	<b>4,778.00</b> <b>562.83</b>	<b>1.96</b> <b>1.95</b>	
245,000	DISCOVER BK GREENWOOD DEL C/D FDIC INS TO LIMITS 254673D52060	2023-05-18	245,000.00	99.3739	243,466	-1,534	-0.63	4,778.00 562.83	1.96 1.95	1.95
<b>Total For Accounts held at JPMS, member FINRA and SIPC</b>			<b>2,455,000.00</b>		<b>2,415,922</b>	<b>-39,078</b>	<b>-1.59</b>	<b>31,434.00</b> <b>3,689.47</b>	<b>1.30</b> <b>1.28</b>	

Report includes Account(s): ...6412, ...6414, ...6415

Please note disclosures and glossary included herein for important information about this report

J.P.Morgan

Cook Memorial Public Library District					
Investment Transaction Schedule - MaxSafe Account - General Fund					
Date	Investment	Transaction Type	Description	MaxSafe Account - General Fund	Interest Income
<b>31-Mar-2022</b>	<b>Ending Balance</b>			<b>4,734,531.93</b>	<b>4,608.79</b>
18-Apr-2022	Maintenance Fee	Fee	Analysis for 03/22	(20.00)	
29-Apr-2022	Wintrust Bank	Interest	For April 2022	1,970.60	1,970.60
<b>29-Apr-2022</b>	<b>Ending Balance</b>			<b>4,736,482.53</b>	<b>6,579.39</b>
<b>13-May-2022</b>	Transfer to Chase Operating A/C	Transfer		(750,000.00)	
31-May-2022	Wintrust Bank	Interest	For May 2022	3,131.79	3,131.79
<b>31-May-2022</b>	<b>Ending Balance</b>			<b>3,989,614.32</b>	<b>9,711.18</b>
17-Jun-2022	Maintenance Fee	<b>Fee</b>	Analysis for 05/22	(20.00)	
30-Jun-2022	Wintrust Bank	Interest	For June 2022	3,834.61	3,834.61
<b>30-Jun-2022</b>	<b>Ending Balance</b>			<b>3,993,428.93</b>	<b>13,545.79</b>

<b>Cook Memorial Public Library District</b>					
<b>Investment Transaction Schedule - MaxSafe Account - Special Reserve Fund</b>					
<b>Date</b>	<b>Investment</b>	<b>Transaction Type</b>	<b>Description</b>	<b>MaxSafe Account - Special Reserve Fund</b>	<b>Interest Income</b>
<b>31-Mar-2022</b>	<b>Ending Balance</b>			<b>1,232,183.73</b>	<b>648.69</b>
29-Apr-2022	Wintrust Bank	Interest	For April 2022	463.91	463.91
<b>29-Apr-2022</b>	<b>Ending Balance</b>			<b>1,232,647.64</b>	<b>1,112.60</b>
31-May-2022	Wintrust Bank	Interest	For May 2022	853.77	853.77
<b>31-May-2022</b>	<b>Ending Balance</b>			<b>1,233,501.41</b>	<b>1,966.37</b>
30-Jun-2022	Wintrust Bank	Interest	For June 2022	1,134.88	1,134.88
<b>30-Jun-2022</b>	<b>Ending Balance</b>			<b>1,234,636.29</b>	<b>3,101.25</b>